

PART NAME	NEMA DIE CAST BOX WITH EMI/RFI SHIELDING	PART No.	ANS-3819 ANS-3819-B	REVISION DATE	-
-----------	--	----------	------------------------	---------------	---

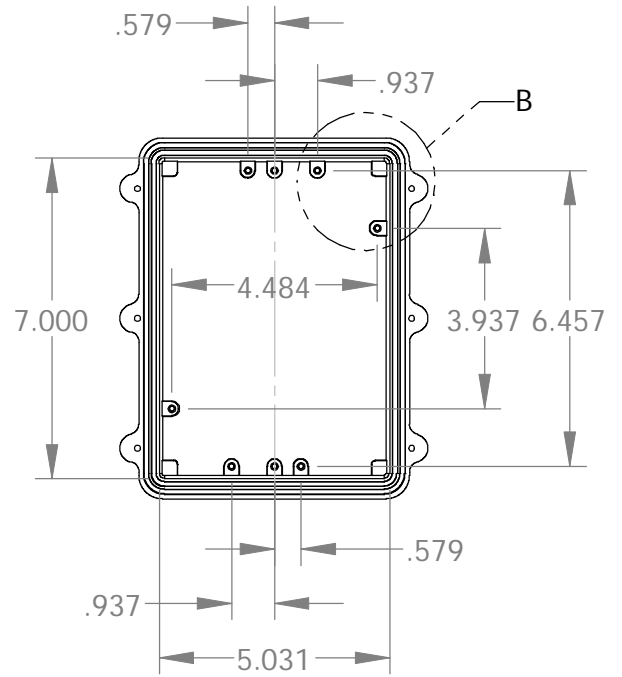

INSIDE BODY DETAILS

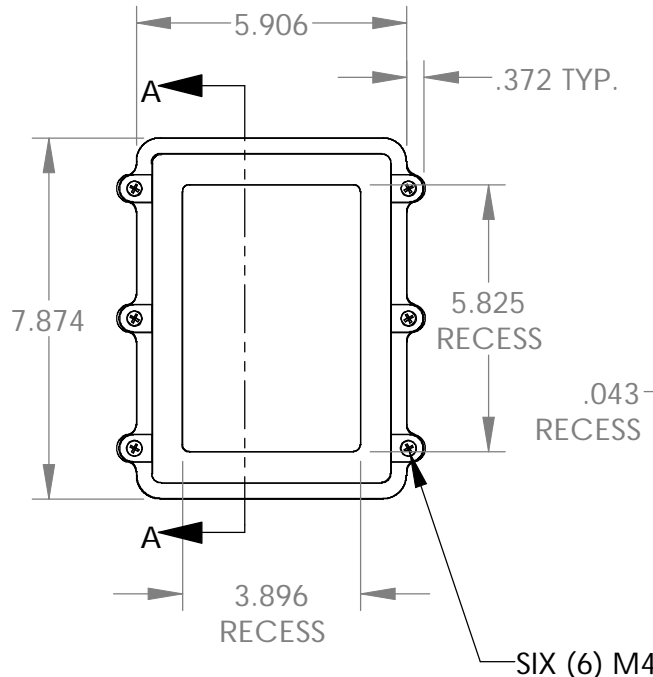

TOP VIEW

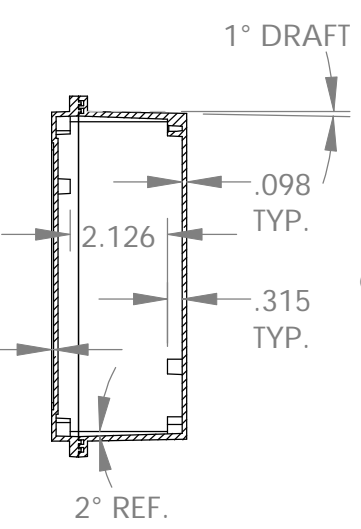

SECTION A-A

SIX (6) M4 x 20mm (.787") LG. STAINLESS STEEL CAPTIVE SCREWS

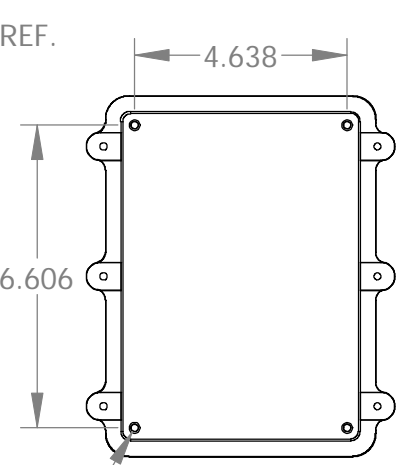

BOTTOM VIEW

Ø.175 x .315 DEEP (4x)
ACCEPTS M5 x 10mm (.394") LG. SELF-TAPPING SCREWS (NOT SUPPLIED)

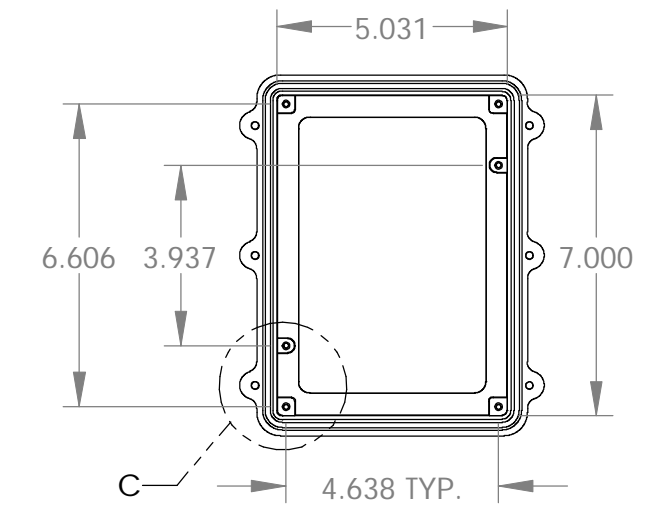

INSIDE COVER DETAILS

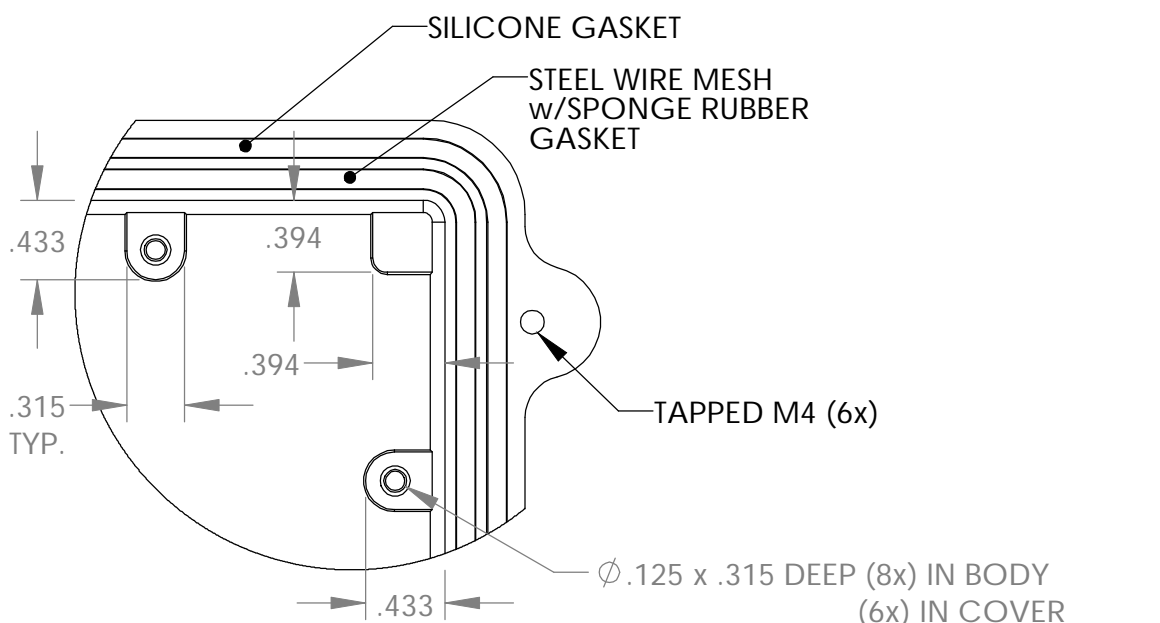
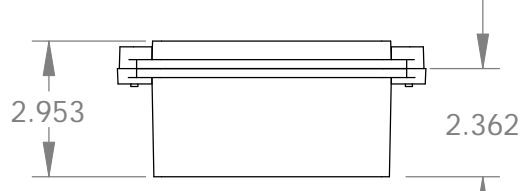

DETAIL B
SCALE 4 : 1

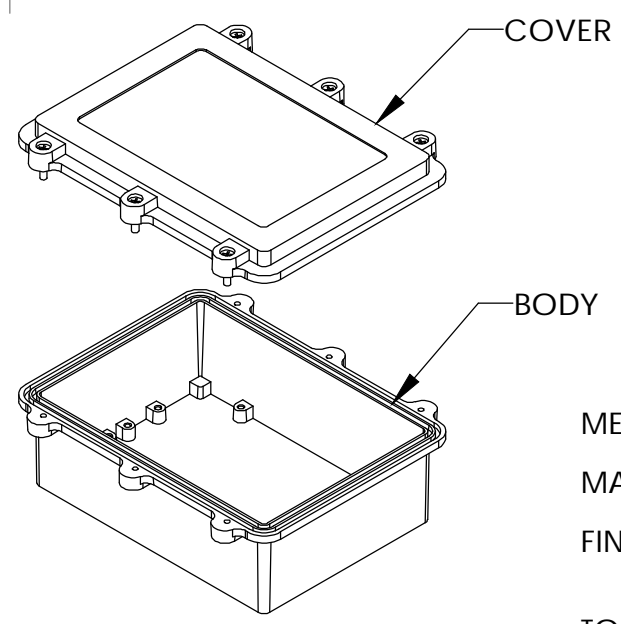

BODY

COVER

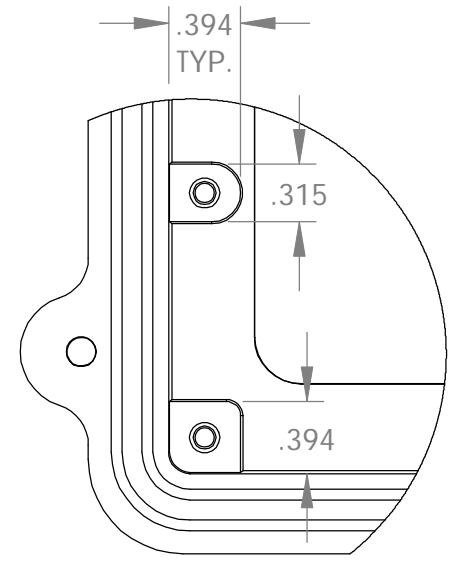

DETAIL C
SCALE 4 : 1

MEETS NEMA 1, 2, 4, 4X, 12, 13 AND IP65 RATINGS
MATERIAL - ALUMINUM ALLOY ADC-12
FINISH - NATURAL (NO SUFFIX PART NO.)
- SMOOTH BLACK (-B SUFFIX PART NO.)
TOLERANCES: ALL HOLE DIAMETERS ±.005
ALL OTHER DIMENSIONS ±.015